



Before use, please take the time to read this datasheet and to make sure you understood the advices and caution of use.



User security

- Do not watch directly the beam of light or through any optical instrument.
- Avoid any contact with the LEDs or its lens.
- Code IP40: protected against solid corpses larger than 1 mm and non-protected against water intrusion.
- Use the product in an environment where the working temperature is between 10°C and +35°C and there is little humid air (<80%): if those conditions are not respected the product can be damaged.
- Do not use the product in an environment where smokes and oil vapors are present.
- Never try to repair by yourself any potential damages on the product.
- Make sure to use the right power supply before connecting the product.
- Do not reverse the electrical polarity – check your connections and the conventions before turning on the product.
- Make sure you have the correct connector to link the product to the power supply.

Any incorrect use cancels the warranty.

Table of contents

User security	1
Eyes & Skin Safety	3
Legal obligations	4
Possible health damages	4
Protective equipment	5
Technical Overview	8
Product reference	9
Optical characteristics	10
Mechanical dimensions	12
How to use: with UPOWER	13
How to use: with a PLC	15
Signals	16
Accessories	17



Eyes & Skin Safety



UWAVE products come under the standard DIN EN 62471:2008 which classified sources of optical radiation into risk groups subject to their potential photo biological hazard. Due to the emission of high UV irradiation, our products belong to Risk Group 3 (hazardous even for momentary exposure) therefore special safety measures, detailed in the following, must be observed.



To protect the eyes and skin staff everyone in the area must wear **protective equipment**. Protective **goggles** should comply with the standard EN 170 (Personal eye-protection - Ultraviolet filters - Transmittance requirements and recommended use). The goggles must protect eyes against direct and side irradiation.



Don't look directly at the product's output window because of a risk of becoming blind.
Don't expose skin too long without protection to avoid skin burning or cancer.



Due to the high emission power, the area near the LEDs can reach high temperature during operation.
Avoid touching directly the product and especially the output window.



Legal obligations

Under the law at present, workers' exposure must be lower than the Exposure Limit Value (Directive 2006/25/EC of the European Parliament). Depending on the wavelength of the product and the body part insolated, **Limit Values are summarized in the tables below:**

	Eye	Skin
Wavelength	315 – 400 nm (UVA)	180 – 400 nm (UVA, UVB, UVC)
Exposure Limit Value	10 000 J/m ²	30 J/m ²

Case study with a LED at 365 nm with an Optical Power of 10 mW/cm²:

For the **eyes**, the maximal exposure time (Δt), the Exposure Limit Value (*ELV*), and the Optical Power (*P*) of a UV product are linked by the formula:

$$\Delta t = \frac{ELV}{P}$$

For **skin**, the Optical Power is normalized by skin's sensitivity factors for each wavelength.

The maximal exposure time per day is calculated below:

	Eyes	Skin
Optical Power (normalized for skin)	10 mW/cm ²	4,7 μW/cm ²
Maximal exposure time per day	1 min 40 s	12 min

Therefore, with a UV product with an optical power of 10 mW/cm², the Exposure Limit Value per day is **reached in 2 minutes for eyes and 12 minutes for skin** without any safety equipment. Therefore, protective equipment is needed.



Possible health damages

Effects on skin along unprotected UV exposure

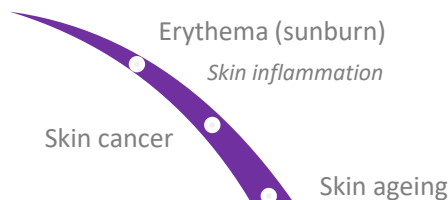

Burning, inflammation, chronic diseases

Effects on eyes along unprotected UV exposure

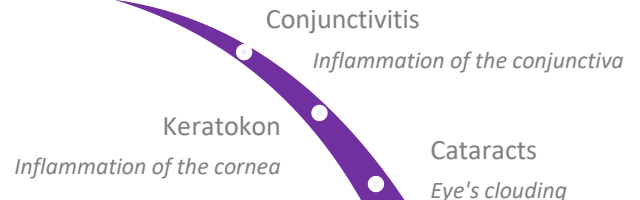

Visual strain, inflammation, blindness



Protective equipment



Eyes protection



Safety goggles prevent UV damages to eyes.

REF: UGLASS-02

- Certified NF EN 170 absorbing 99,9% of UV radiation and visible light up to 532nm
- Protect against side irradiation
- Resist to chemical products and scratches

Beyond 2 minutes per day of eye UV LED exposure at 10 mW/cm², protective goggles are necessary according to the European Directive 2006/25/EC.



Safety face shield prevents UV damages to eyes and skin's face.

REF: UMASK-01

- Certified NF EN 170 absorbing 99,9% of UV radiation and visible light up to 400nm
- Protect against side irradiation
- Resist to scratches

Beyond 12 minutes per day of face UV LED exposure at 10 mW/cm², protective mask is necessary according to the European Directive 2006/25/EC.



Body protection



Safety gloves prevent UV damages to exposed skin.

REF: UGLOVE-01

- High protection against UV radiation
- Resist to chemical products and scratches

Beyond 12 minutes per day of hands UV LED exposure at 10 mW/cm², protective gloves are necessary according to the European Directive 2006/25/EC.



Safety jacket and trousers prevent UV damages to exposed skin, especially arms & legs.

- Certified UPF 50+ absorbing more than 90% of UV radiation
- Durable and resistant

REF (jacket): UJACK-01

REF (trouser): UTROUS-01

Beyond 12 minutes per day of arms & legs UV LED exposure at 10 mW/cm², protective clothes are recommended according to the European Directive 2006/25/EC.



Protection suit prevents UV damages to entire body, especially neck.

REF: USUIT-01

- Certified UPF 50+ absorbing more than 90% of UV radiation
- Resist to chemical products

Beyond 12 minutes per day of neck UV LED exposure at 10 mW/cm², protective suit is recommended according to the European Directive 2006/25/EC.



UV source isolation



UV shields are protective windows which isolate the UV insulated zone to protect all workers around.

They are made to measure to fit with your constraints.

REF: USHIELD-01

Beyond 2 minutes per day of eye UV LED exposure and 12 minutes of skin UV exposure at 10 mW/cm², protective shields are necessary to protect staff without safety equipment according to the European Directive 2006/25/EC.



Warning stickers



Warning stickers inform workers of radiation danger and invite them of wearing protection equipment. They are available in 3 sizes:

- 55 mm x 25 mm
- 165 mm x 75 mm
- 290 mm x 130 mm

REF: USTICK-01

REF: USTICK-02

REF: USTICK-03



Expertise

Our UV LED experts from UWAVE can come and check your production lines to:



Measure UV irradiance to **determine the maximum UV personal exposure time** compared with limits (European Directive 2006/25/EC)







Determine the most **adapted solution** to protect workers' eyes and skin.



Contact us to get our expertise. We will find together the equipment which fits with your application.



Technical Overview

Electronics 	<i>Power supply</i>	24V DC
	<i>Illumination mode</i>	Continuous with a DIM process [0-24V]
	<i>Connector</i>	M12 5 pins
	<i>Power consumption</i>	35 W
	<i>Response time</i>	50 µs
Optics 	<i>Wavelength</i>	365, 385, 395 or 405 nanometers
	<i>Irradiance</i>	Up to 3650 mW/cm ² for 385, 395 and 405 nm Up to 3300 mW/cm ² for 365 nm
Mechanics 	<i>Width and height</i>	65 mm x 65 mm
	<i>Length</i>	172 mm
	<i>Material</i>	Device body: Aluminum alloy
	<i>Weight</i>	860 g
Thermal 	<i>Cooling system</i>	Active air cooling with fan
Environment 	<i>Working temperature</i>	10°C to 35°C
	<i>Working humidity</i>	< 80% for temp < 30°C
	<i>IP code</i>	IP40



Product reference

USPOT - **XXX***

365

385

395

405

*XXX corresponds to the wavelength of the product.



Optical characteristics

Spectra

Spectra of USPOT 365, 385 and 405

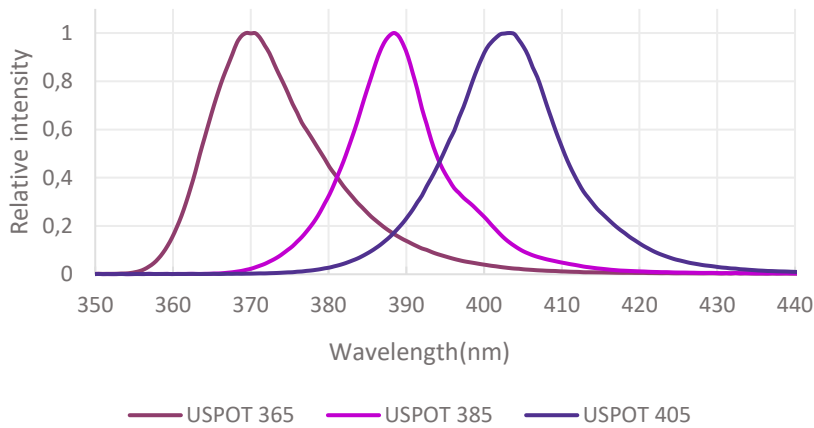

	Pic Wavelength	Full width at half maximum
USPOT 365	370 nm	12 nm
USPOT 385	388 nm	10 nm
USPOT 405	403 nm	15 nm

Size of the exposed area

In the following graph, the spot size is the exposed area where the irradiance is higher than 50% of the maximum irradiance. This graph is the same for all wavelength.

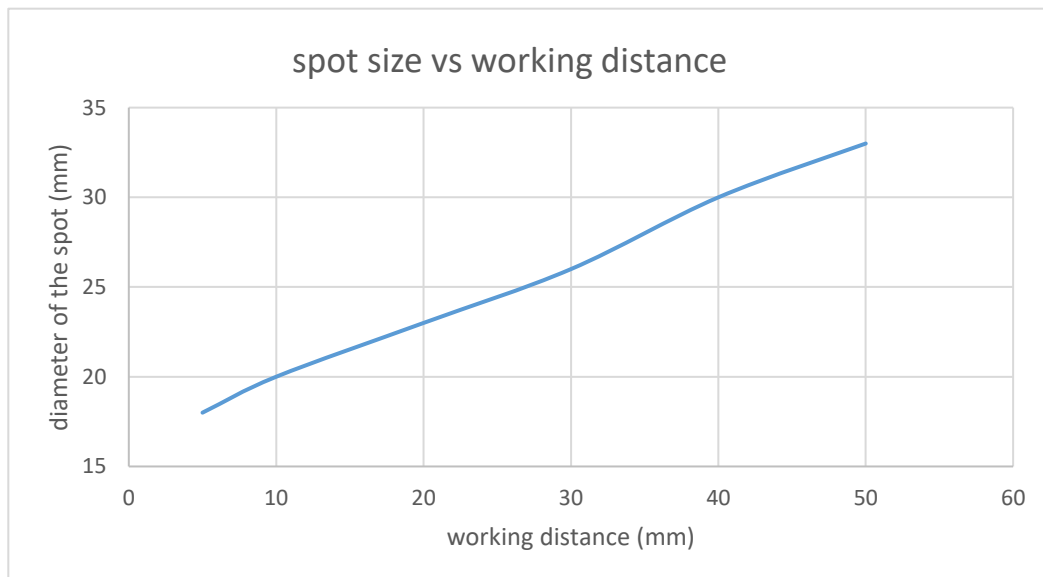

Photometry

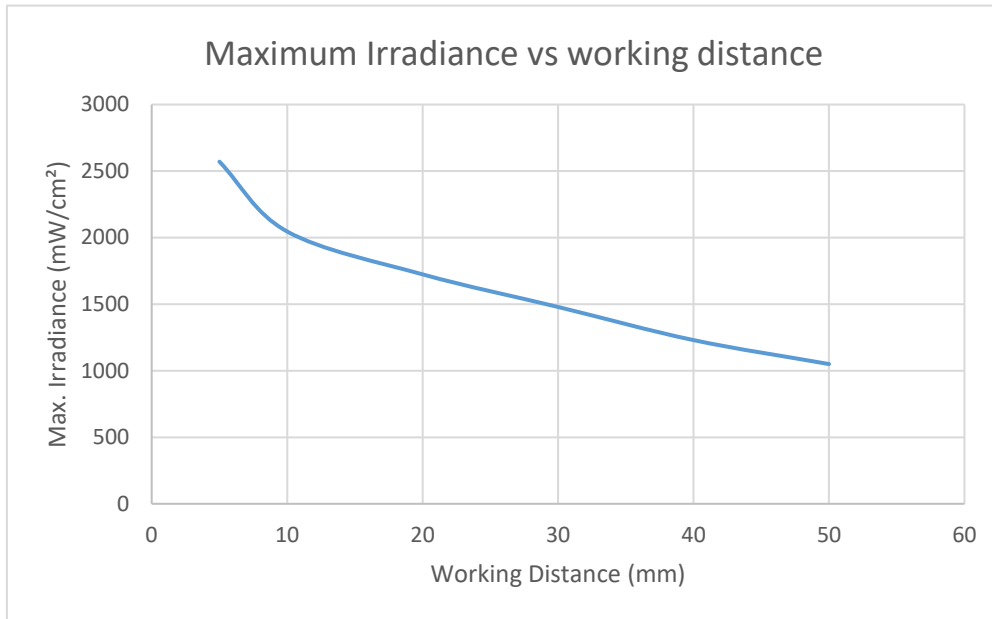

This figure is plotted with USPOT-365.



Mechanical dimensions

2 x \varnothing 5,80 A TRAVERS TOUT
□ \varnothing 10 ∇ 63

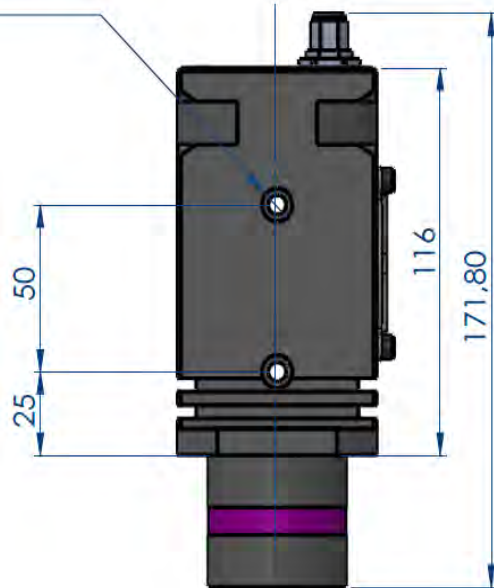

8 x \varnothing 2,50 ∇ 8,50
M3 - 6H ∇ 6

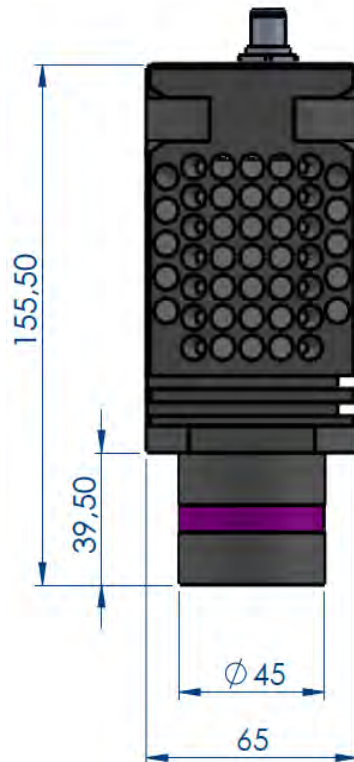
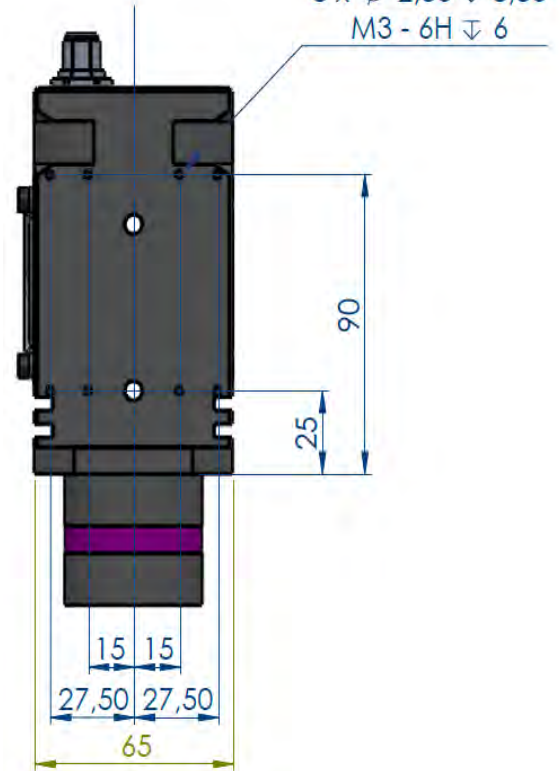



How to use: with UPOWER

The USPOT™ can be provided with its power supply UPOWER™

Steps	Illustrations
<p>Fix the product using the dimensions given in the “mechanical considerations” part (pay attention to leave a 10 cm space next to mechanicals holes for ventilation).</p>	
<p>Connect the cable M12 - 5 pins between the USPOT™ and the UPOWER™.</p>	
<p>Plug the UPOWER to a 230V outlet.</p>	
<p>The USPOT™ is ready to be used. To turn the USPOT™ ON, you can either use the buttons ON on the UPOWER, or connect the UPOWER to your PLC.</p>	<p>STOP button ON button</p>
<p>How to choose the light intensity Use the light intensity controller buttons on the UPOWER to control the light intensity from 20% to 99%.</p>	<p>Light intensity controller</p>

How to choose the exposure time

Use the TIMER interface on the UPOWER to choose the exposure time. The red timer is fixed, and the orange timer is the one that you can change. To validate the time, push the reset button on the timer.

How to lock the UPOWER

Turn the lock key in order to lock the timer configuration. The word "LOCK" appears on the timer screen.





How to use: with a PLC

Standard version

The USPOT™ can be used without the UPOWER™ in order to directly supply it by yourself by using a PLC. To connect your PLC to the UV product, use the cable by following the board below.



M12 5 pins

Pin number	Cable color	Input / Output signal	Designation	Signal
1	Brown	In	Power supply +	24V
2	White	Out	Temperature +	Reading of the thermistor value
3	Blue	In	Power supply -	0V
4	Black	In	Intensity Control - DIM	0 – 24V or look at the graph below
5	Grey	Out	Temperature -	Reading of the thermistor value

For more details about the several signals emitted, check out the section “signals”.

Smart version

Pin number	Cable color	Input / Output signal	Designation	Signal
1	Brown	In	Power supply +	24V
2	White	Out	UV LED ON	24V if UV LED ON 0V if UV LED OFF
3	Blue	In	Power supply -	0V
4	Black	In	Intensity Control - DIM	0 – 24V or 0-10V or 0-5V direct or indirect
5	Grey	Out	Temperature error	24V if temperature ok 0V if the USPOT is overheating



Signals

Intensity Control

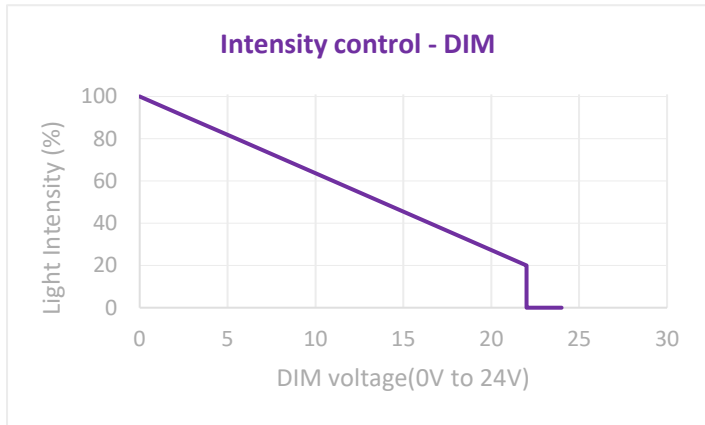

The USPOT™ is supplied with a 24V constant voltage source.

Using the DIM pin, the light intensity can be controlled:

- 0V – ON (100%)
- 0V to 22V – 100% to 20%
- 22V to 24V – OFF (0%)

Max DIM power consumption: 85 mW

For other intensity control configuration, feel free to ask us.

Thermistor Value

This product has a thermistor giving the temperature value near the LEDs. The thermistor value can be read using the pins **2** and **5**. You can find the board of conversion on the manufacturer website: Vishay, using the reference of the supplier: NTCS0805E3103JMT.

Example of values:

Temperature °C	Resistance value (ohms)
10,0	18514,6
15,0	14985,6
20,0	12205,1
25,0	10000,0
30,0	8240,3
35,0	6827,5
40,0	5686,6
45,0	4760,3
50,0	4004,2



Accessories

Name and Photo	Description
<p>Cables for the USPOT™</p> 	<p>Both sides connectors (UPOWER™ link):</p> <p>Reference: UCAB-M12-FD-5-D-L5 } 2 } Depending on 10 } the length you } want (in meters)</p> <p>One side with bare wire (towards PLC):</p> <p>Reference: UCAB-M12-FM-5-DD-L5 } 2 } Depending on 10 } the length you } want (in meters)</p>